



32 oz Pathology Container

Product Code: 0432-1100

General Description

- Color: Translucent
 Body Diameter: 117.6 mm
 Body Height: 122.4 mm
- Snap-on lid creates secure seal
 - Shatter-resistant, translucent body allows for easy viewing

Material:

HDPE, FDA Certified
 Country of Origin: China
Product is recyclable



- Case: 100 pc/case
 Packaged: 100 Bagged
 Case Dimensions: 19.25 x 14.50 x 13.25"
 Case Weight: 13 lbs
 Cube Dimension: 2.14
 Cases per Skid: 30

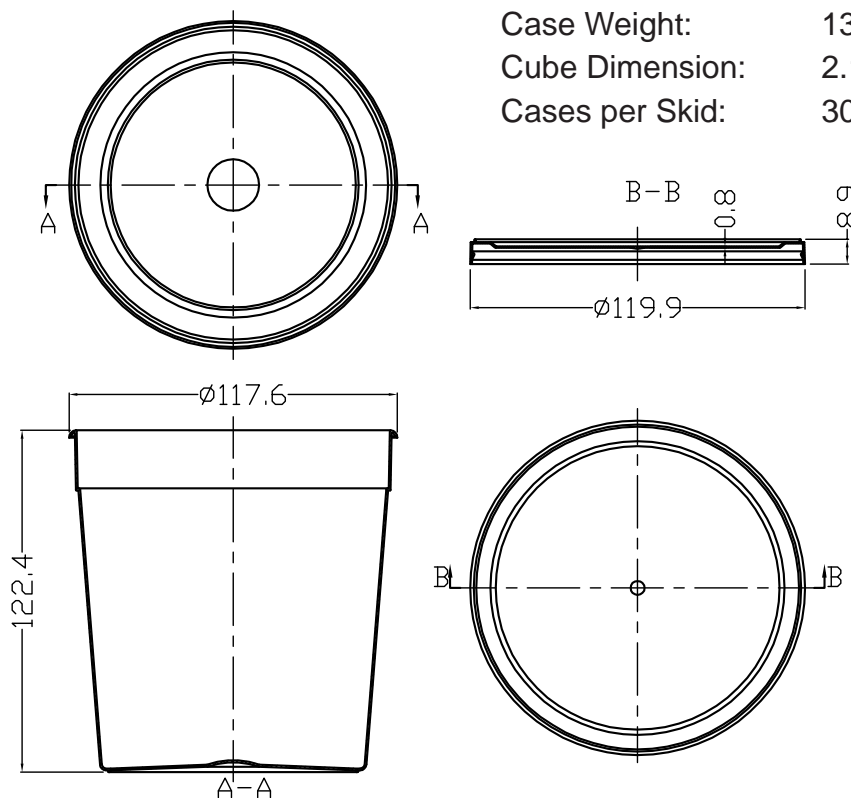

Manufactured by Oak Ridge Products, LLC
 FDA Manufacturing Facility Registration
 #1419823 & 3006060667

Product dimensions listed are in millimeters

OAK RIDGE PRODUCTS, LLC.
 ALL RIGHTS RESERVED

US: 888-650-7444 INT'L: 001-815-363-4700
 WWW.OAKRIDGEPRODUCTS.COM

REV. 1/10/14