



# 174 oz Pathology Container

Product Code: 0495-1100



## General Description

Color: Translucent  
Body Diameter: 223.2 mm  
Body Height: 179.8 mm

- Snap-on lid creates secure seal
- Shatter-resistant, translucent body allows for easy viewing

### Material:

HDPE, FDA Certified  
Country of Origin: China  
*Product is recyclable*

Case: 25 pc/case  
Packaged: 25 Bagged  
Case Dimensions: 26.25 x 18 x 11"  
Case Weight: 12.25 lbs  
Cube Dimension: 3.01  
Cases per Skid: 20

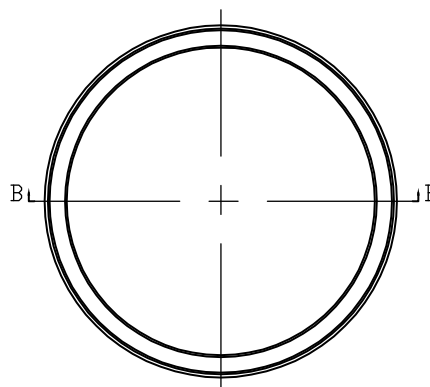
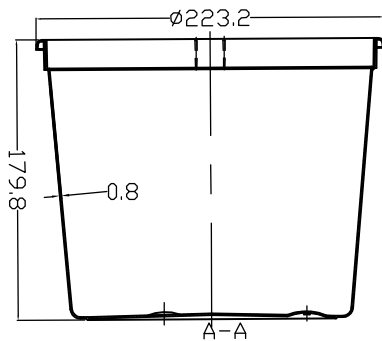
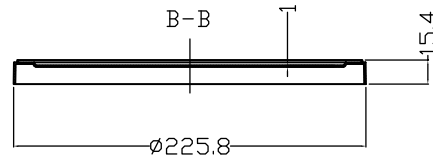
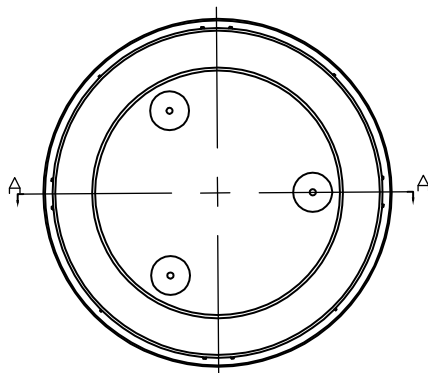

Manufactured by Oak Ridge Products, LLC  
FDA Manufacturing Facility Registration  
#1419823 & 3006060667

Product Dimensions listed are in millimeters