



1 Gallon Sharps Container

Product Code: 0319-1500

General Description

- Designed for Multi purpose use.
- Slide window maximizes usable container volume for larger sharps
- Shatter & Puncture-resistant
- Locks for final disposal

Material:

High Impact Polypropylene
Country of Origin: China

Product is recyclable

Packing Details

Case:	32 each/case
Packaged:	Bulk, Nested
Case Dimensions:	21.5 x 21.125 x 15.5"
Case Weight:	23 lbs
Cube Dimension:	4
Cases per Skid:	32

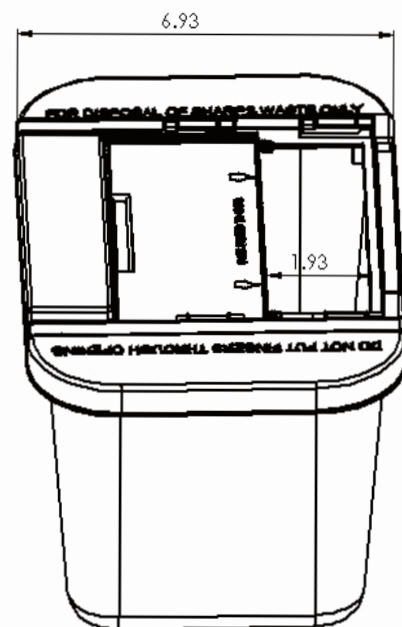
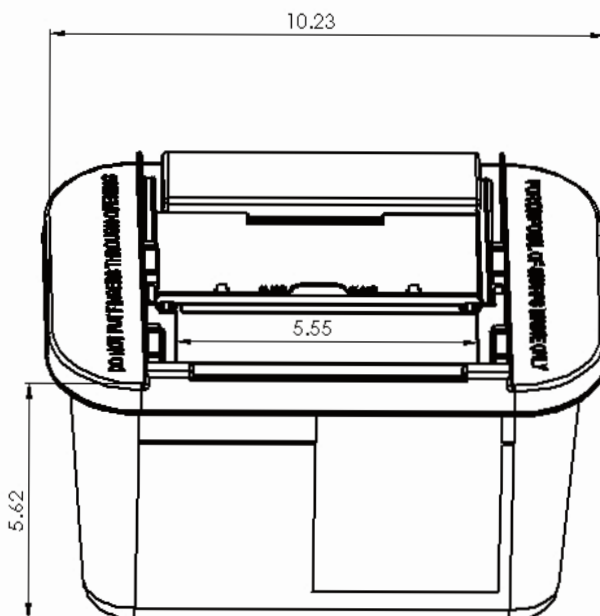

Manufactured by Oak Ridge Products, LLC
FDA Manufacturing Facility Registration
#1419823 & 3006060667

Product dimensions listed are in inches

OAK RIDGE PRODUCTS, LLC.
ALL RIGHTS RESERVED

WWW.OAKRIDGEPRODUCTS.COM

US:888-650-7444 INT'L:001-815-363-4700
REV. 1/10/14