



7 ml Vial with Cap

Product Code: 0207-0100



General Description

- Cap seal per ASTM D3078 to 95kPa
- Ideal for general purpose storage and transportation
- Conical bottom for centrifuge
- Cap & vial packaged separately

Material:

Polypropylene Body, FDA Certified
 HDPE Cap, FDA Certified
 Country of Origin: Hungary
Product is recyclable

Packing Details

Case:	2000 pc/case
Packaged:	2000 Bagged
Case Dimensions:	24 x 15 x 9"
Case Weight:	14.5 lbs.
Cube Dimension:	1.88
Cases per Skid:	40

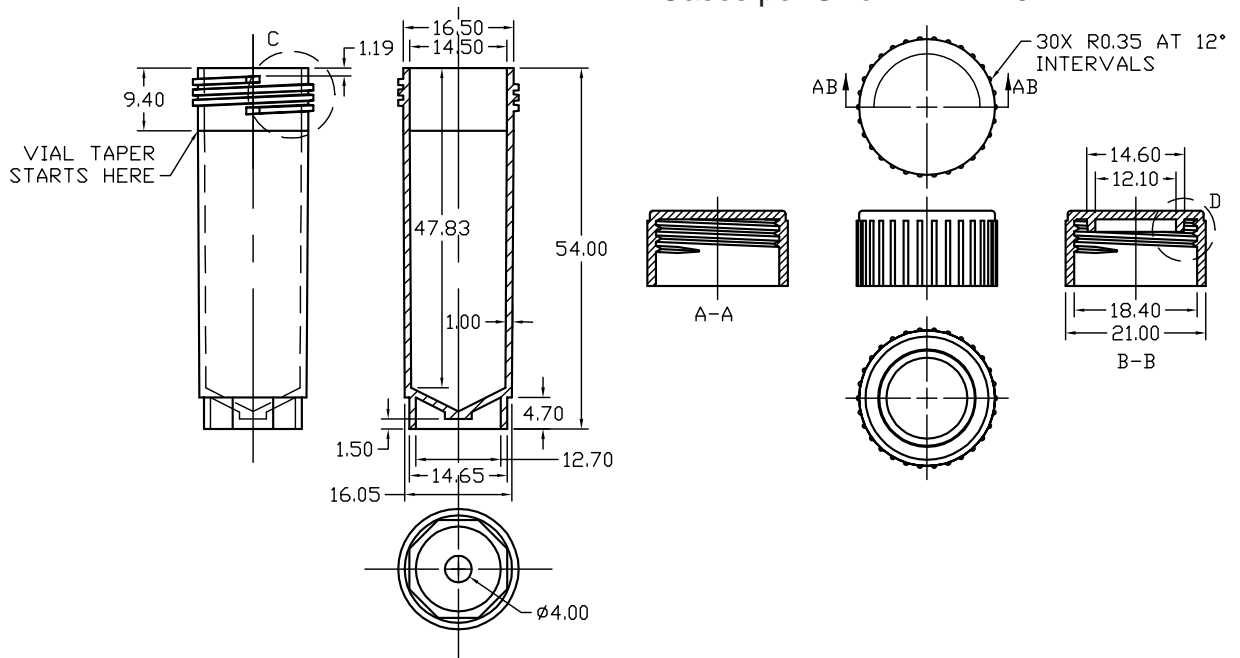

Manufactured by Oak Ridge Products, LLC
 FDA Manufacturing Facility Registration
 #1419823 & 3006060667

Dimensions listed are in millimeters

OAK RIDGE PRODUCTS, LLC.
 ALL RIGHTS RESERVED

US:888-650-7444 INT'L:001-815-363-4700
 WWW.OAKRIDGEPRODUCTS.COM

REV. 1/10/14