



20 mL Vial with Cap

Product Code: 0620-0300

General Description

- Cap seal per ASTM D3078 to 95kPa
- Ideal for general storage and transportation
- Cap & Vial Packaged separately



Material:

Polypropylene Body, FDA Certified
HDPE Cap, FDA Certified
Country of Origin: China
Product is recyclable

Packing Details

Case:	1000 pc/case
Packaged:	Individually Bagged
Case Dimensions:	24 x 16.50 x 12"
Case Weight:	23.65 lbs
Cube Dimension:	2.67
Cases per Skid:	24

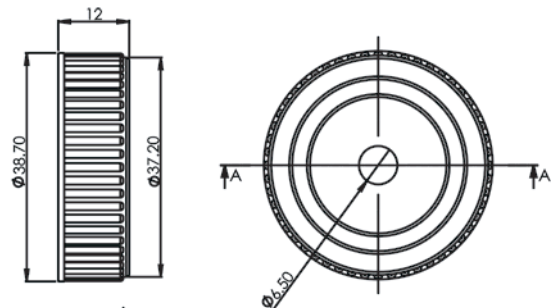
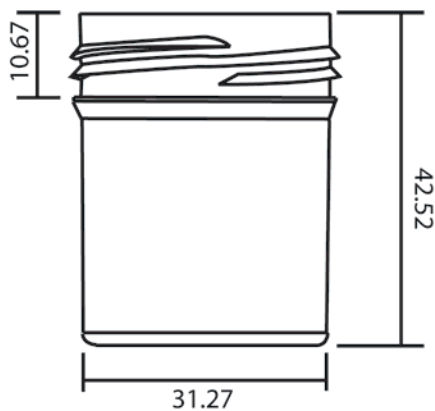

Manufactured by Oak Ridge Products, LLC
FDA Manufacturing Facility Registration
#1419823 & 3006060667

Dimensions listed are in millimeters

OAK RIDGE PRODUCTS, LLC.
ALL RIGHTS RESERVED

US:888-650-7444 INT'L:001-815-363-4700
WWW.OAKRIDGEPRODUCTS.COM

REV. 1/10/14