



30 ml Vial With Fecal Spork

Product Code:

0631-0300 (White cap)

0631-0400 (Blue cap)



General Description

- Ideal for general purpose storage and transportation
- Conical bottom for centrifuge
- Cap & vial packaged separately

Material:

Polypropylene Body, FDA Certified
 HDPE Cap, FDA Certified
 Country of Origin: China
Product is recyclable

| | |
|------------------|------------------------|
| Case: | 500 pc/case |
| Packaged: | 500 Bagged |
| Case Dimensions: | 12.50 x 12.50 x 21.25" |
| Case Weight: | 13.8 lbs. |
| Cube Dimension: | 1.92 |
| Cases per Skid: | 36 |

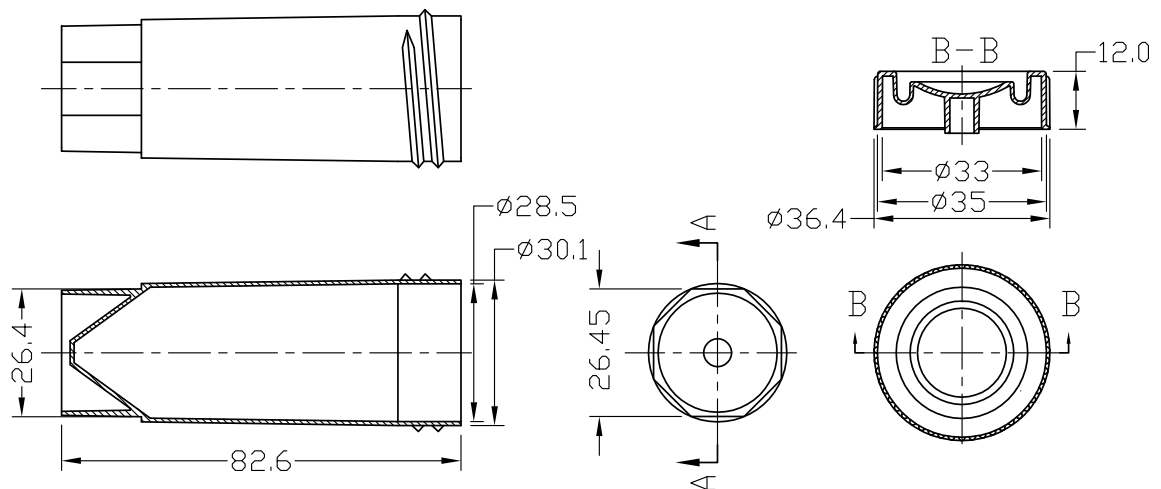

Manufactured by Oak Ridge Products, LLC
 FDA Manufacturing Facility Registration
 #1419823 & 3006060667

Product dimensions listed are in millimeters

OAK RIDGE PRODUCTS, LLC.
 ALL RIGHTS RESERVED

US:888-650-7444 INT'L:001-815-363-4700
 WWW.OAKRIDGEPRODUCTS.COM

REV. 1/10/14