



# 250 ml Histology Container

**Product Code:**

- 0627-1300 (White cap)
- 0627-1600 (Yellow cap)

**General Description**

- Ideal for specimens and general purpose storage and transportation
- Shatter-resistant, translucent body
- Screw on lid creates secure seal



**Material:**

Polypropylene Body, FDA Certified  
 HDPE Cap, FDA Certified  
*Product is recyclable*

**Packing Details**

Case:	100 pc/case
Packaged:	10/sleeve, 10 sleeves
Case Dimensions:	19 x 8 x 16"
Case Weight:	10.75 lbs.
Cube Dimension:	1.41
Cases per Skid:	48

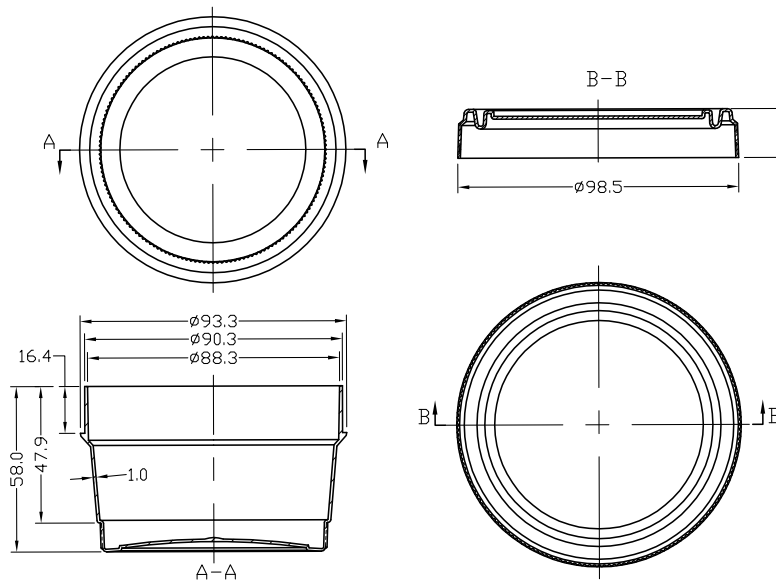

Manufactured by Oak Ridge Products, LLC  
 FDA Manufacturing Facility Registration  
 #1419823 & 3006060667

Dimensions listed are in millimeters

OAK RIDGE PRODUCTS, LLC.  
 ALL RIGHTS RESERVED

US:888-650-7444 INT'L:001-815-363-4700  
 WWW.OAKRIDGEPRODUCTS.COM

REV. 10/1/13