



Single Microscope Slide Holder

Product Code:

1001-0100 (Translucent)

1001-0400 (Blue)

General Description

- Fits one standard 22x75mm slide
- Easy-to-open tabs, securely protects enclosed slides
- Sturdy, crack-resistant construction for added protection and durability

Material:

Polypropylene, FDA Certified

Country of Origin: China

Product is recyclable



Packing Details

Case:	1000 pc/case
Packaged:	4 Boxes of 250
Case Dimensions:	17 x 9 x 13.75"
Case Weight:	16.55 lbs.
Cube Dimension:	1.22
Cases per Skid:	50

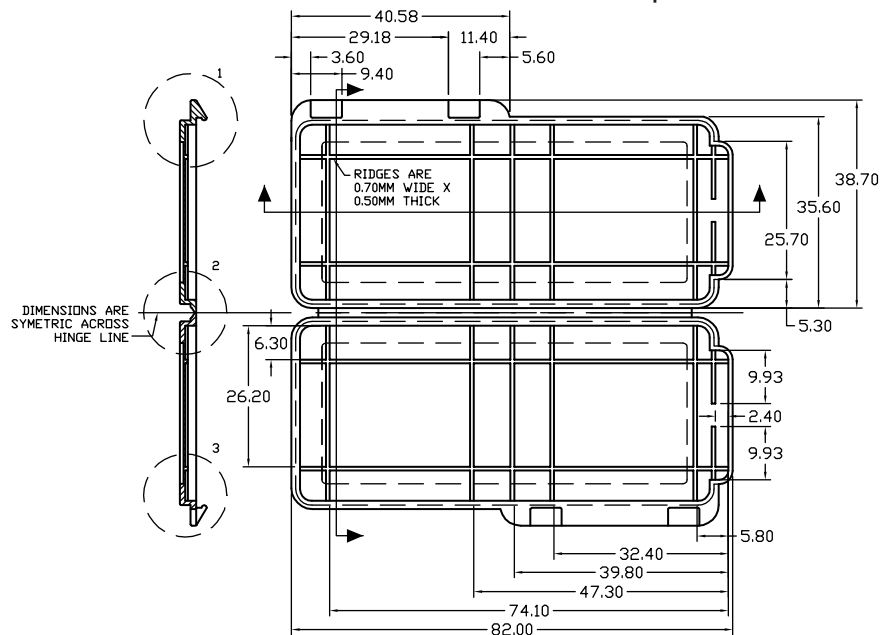

Manufactured by Oak Ridge Products, LLC
 FDA Manufacturing Facility Registration
 #1419823 & 3006060667

Dimensions listed are in millimeters

OAK RIDGE PRODUCTS, LLC.
 ALL RIGHTS RESERVED

US:888-650-7444 INT'L:001-815-363-4700
 WWW.OAKRIDGEPRODUCTS.COM

REV. 1/10/14