



1qt Phlebotomy Sharps Container

Product Code: 0310-1500

General Description

Designed for use by Phlebotomists or others who need a small transportable container

- Shatter-resistant, Puncture resistant, transparent lid allows for easy viewing

Material:

High Impact Polypropylene
Country of Origin: China

Product is recyclable

Packing Details

Case:	80 sets/case
Packaged:	Each
Case Dimensions:	18.5 x 14.125 x 18.5"
Case Weight:	22.7 lbs
Cube Dimension:	2.79
Cases per Skid:	24

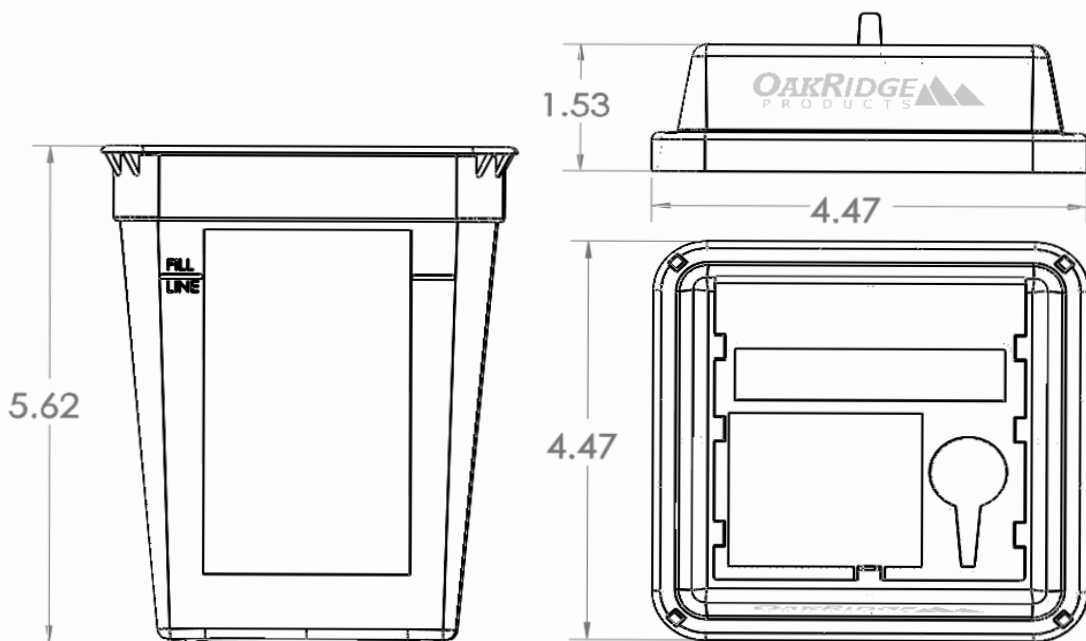

Manufactured by Oak Ridge Products, LLC
FDA Manufacturing Facility Registration
#1419823 & 3006060667

Product dimensions listed are in millimeters

OAK RIDGE PRODUCTS, LLC.
ALL RIGHTS RESERVED

US:888-650-7444 INT'L:001-815-363-4700
WWW.OAKRIDGEPRODUCTS.COM

REV. 1/10/14